

ezSystem elab16m Project 3s: Fridge Alarm

Project description:

The project is a fridge alarm that uses the elab16m, a Light Dependent Resistor (LDR), a yellow LED, a red LED, a buzzer and a Temperature Sensor.

When the fridge door is opened the LDR senses the light in the fridge and activates a buzzer and a LED as a “door open” alarm.

1. Design the Fridge Alarm

Use ezCircuit Designer to construct an input/output (I/O) diagram

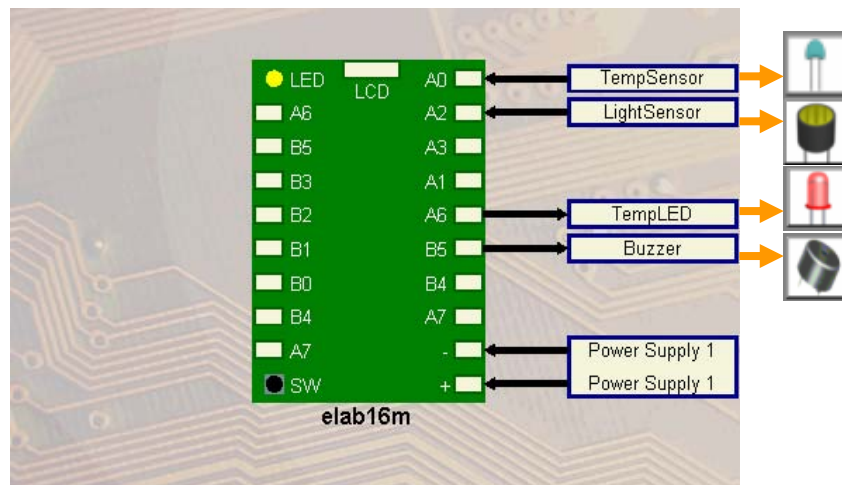

2. Build the Fridge Alarm

Use ezCircuit Designer I/O diagram to connect the hardware

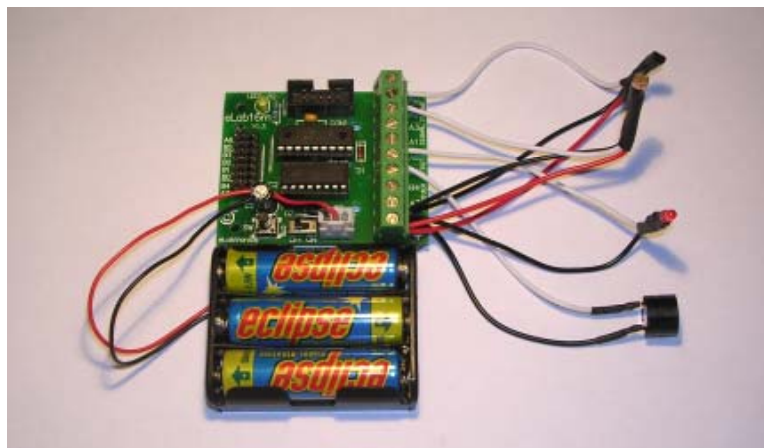

3. Program the Fridge Alarm

Use ezCoreChart to program the functions of the fridge alarm

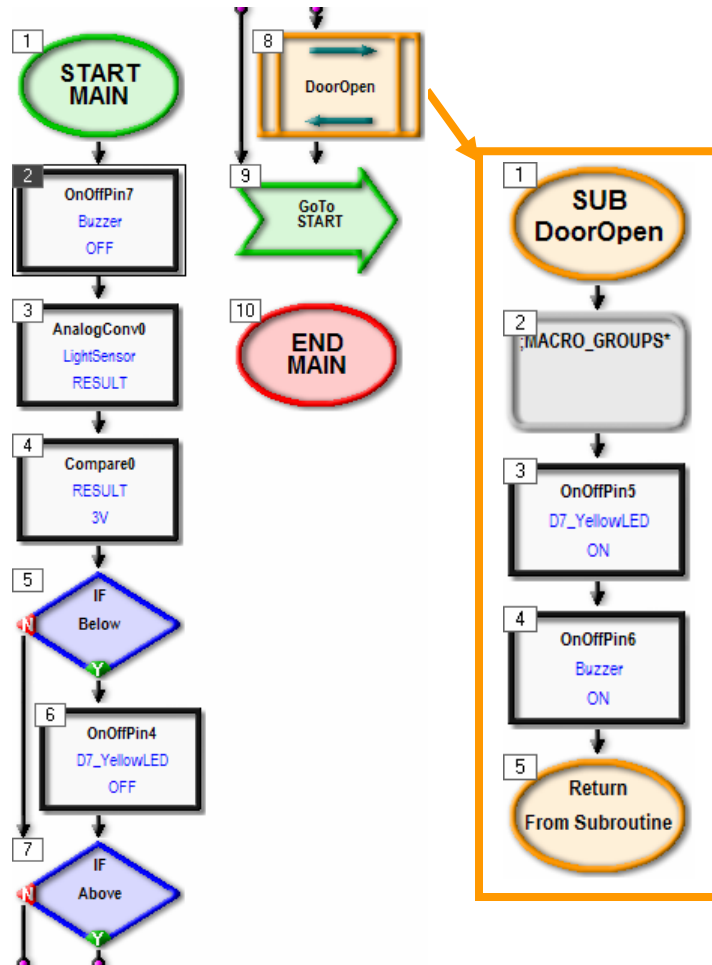

Extension:

1. Modify the fridge alarm program so that the alarm is activated after the fridge door has been opened for more than five seconds. The time delay of five seconds should only occur when the door is opened and not any other time in the program.

Hint: The subroutine group called “Door_Open” is a good place to make this change

2. Add the temperature sensing feature so that when the temperature is above a set point the buzzer and the “TempLED” will turn on. The system will still continue to check if the door is opened even when the temperature alarm is activated.

Hints:

- The program for the temperature alarm is similar to the part of the program for the door open alarm using the LDR as light sensor.
- Create a subroutine group of all the icons used for the door open alarm called “Check_Door” so that the program is easier to understand.

Important: The set point value of the temperature sensor will need to be adjusted depending on the room temperature. Start with a “compare with” value of 1.0.